

1 Install Junction Box

Install under dash
 Note: Allow air space around heat sink

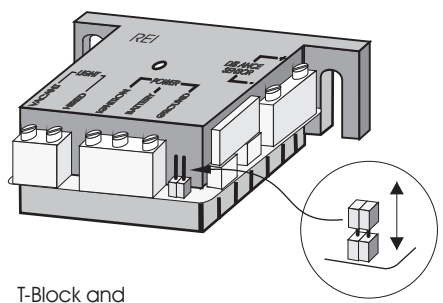

T-Block and Chrysler & GM Cars: - Use jumper
 Ford Cars: - Remove jumper

2 Install Mounting Bracket

Install onto dash or other convenient location. Metal bracket can be used where necessary.

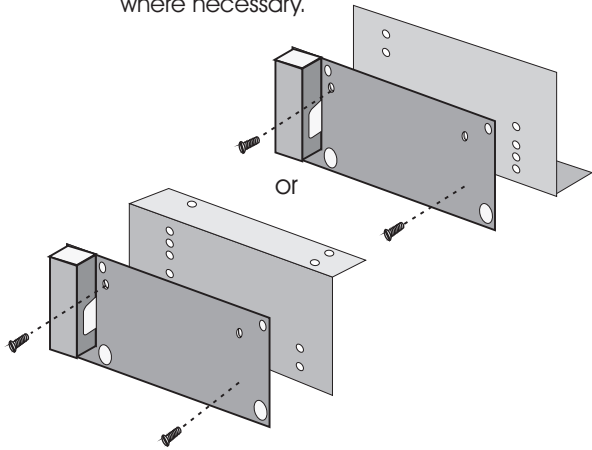

3 Electrical Hook-Up

Power connections:

- BATTERY terminal on junction box powers the meter. (3 Amp fuse protects meter)
- IGNITION terminal on junction box powers the roof light. (must be fused through an in-line fuse (10 Amp))

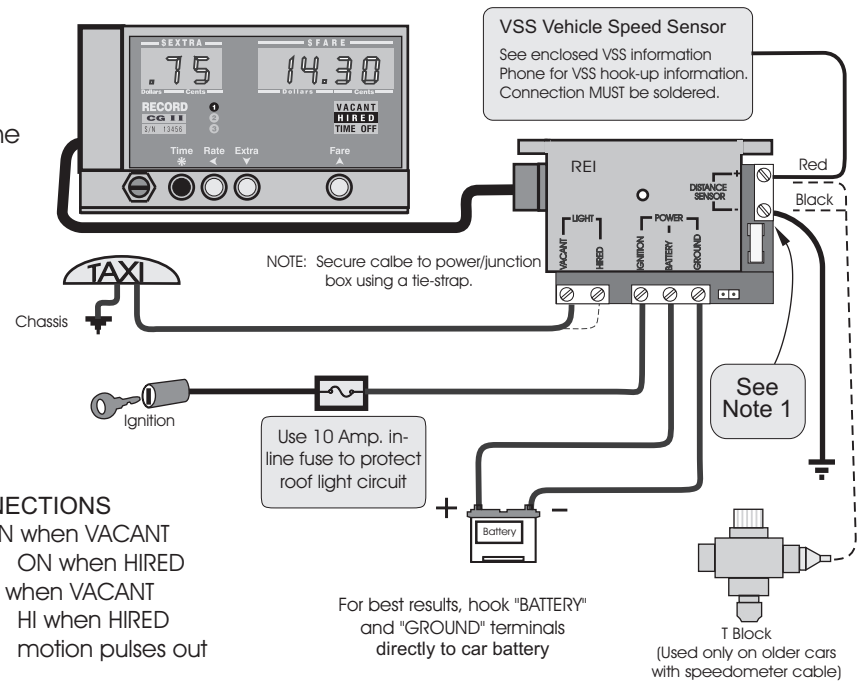

JUNCTION BOX CONNECTIONS

LIGHT VACANT	ON when VACANT
LIGHT HIRED	ON when HIRED
DISPATCH VACANT	HI when VACANT
DISPATCH HIRES	HI when HIRED
MOTION	motion pulses out

For best results, hook "BATTERY" and "GROUND" terminals directly to car battery

T Block (Used only on older cars with speedometer cable)

NOTE 1: Junction Box REV. G and subsequent MUST have a separate ground wire for mileage to work.

4 Programming

1. Make sure meter and wiring are properly installed as per steps 1,2, and 3.
2. Remove safety seal, seal screw, and hex insert.
3. Turn power to the meter ON and set meter to VACANT mode.
4. Temporarily insert rate setting pins into the small holes in hex insert slot. (See back page) Meter should read: **FARES**
5. To start programming rates, press * button. Enter rates using the 4 buttons as follows:
 Press * button to enter or leave memory
 Press ▲ button to increase the value of the flashing number
 Press ▼ button to decrease the value of the flashing number
 Press ◀ button to move flashing digit to the next number on the left.
 Procedure: use the ▲, ▼, ◀ buttons until meter reads the wanted value.
 Press * button to enter the value into memory.

6. Program rates as follows:

Example rate	Meter shows	Enter Function	
a) 1	nr	1	Number of rates to program (Max. of 3)
b) \$.cnts	dp	2	Decimal point location from R.H. e.g. 2 = \$\$\$\$.¢¢
c) \$0.25	et	0.25	Extras charge (0.00 will omit extras)
d) \$1.00	et	1.00	Total allowed extras.
e) 12345	cn	23456	Cab Number (maximum of 6 digits)
f) 7% tax	ta	7.00	Tax in % to be displayed. To omit tax display, program ta = 0.00 and et = 0 in step f and g). Tax Type. If tax display desired in step 6f), then: 0 entry will split out tax at end of fare 1 entry will add tax at end of fare.
g) Tax in or add	et	0 or 1	
h) 0.0	dc	0.0	Distance controlled rate change (not used in regular rates)
i) \$2.10	11	2.10	Flag rate
j) \$24/Hr.	1t	24.00	\$ charge per hour
k) 105 meters	1d	0.1050	First drop distance, in meters or decimal fraction of mile or kilometer. *(See Note 1).
l) 105 meters	12d	0.1050	Following drop distances.
m) \$0.10	12	0.10	Fare increments

If single rate is selected (step 6a), proceed with steps 8 and 9 (DO NOT complete step 7)
 If more than one rate is selected (step 6a), proceed with step 7, then 8 and 9.

7. If more than 1 rate was selected in step 6a) (nr 2 or 3), meter reads **21**, flag for rate 2
 Program 5 values for rate 2 as per steps 6h)-m) **21**, **2t**, **2d**, **22d**, & **22**
 Program 5 values for rate 3 as per steps 6h)-m) **31**, **3t**, **3d**, **32d**, & **32**

8. After last entry, meter returns to **nr** (Step 6a) and reviews all values in memory. If any value is incorrect, reprogram meter starting at step 4.

9. After rates review, meter shows **000** **000000** and blanks, indicating that programming is completed.

* Note 1: For example, to find decimal equivalent of 1/9 of a mile or kilometer, With a calculator, divide 1 by 9: 1 / 9 = 0.1111111. Round off answer to 4 decimal places = 0.1111: This is the correct value to enter.

5

Calibration

- Remove seal screw and hex insert
 - a) Temporarily insert rate setting pins into the small holes in hex insert slot.
 - Meter reads: RATES
 - b) Press \blacktriangledown Button. Meter reads: CAL
 - c) Press \ast Button. Meter reads: F1 2 (Min. 0 - Max. 7)
(filter value 2 is the correct setting for nearly all cars, (See Note 1))
 - d) Press \ast Button. Meter reads: 1250
- Drive to the start point of your test distance (1 Km or 1 mile) and stop.
- Press \blacktriangle Button. Meter reads: 0 & HIRED
- Drive the test distance. Meter is counting the mileage pulses. At the end of the test distance, stop the car.
- Press \blacktriangle Button. Meter reads the correct calibration number for your car and VACANT
(See Note 2)
- Write down number for later reference.
- Press \ast Button. This enters the calibration number in the memory.
Meter returns to VACANT mode indicating calibration is completed.

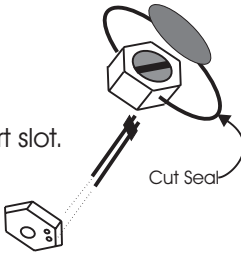

NOTE 1: Filter F1 and calibration number must have a value entered for Mileage Charges to work.
 NOTE 2: Factory standards for all cars are 2000, 4000, or 8000 pulses/mile or 1250, 2500, or 5000 pulses/Km. The calibration number for your car should be relatively close to one of the above numbers. If it is not, the calibration might be wrong. If the test run is repeated, the calibration number should remain the same.

To program a previously known calibration number:

- Repeat steps a) to d) above.
- Press \blacktriangledown Button.
- With the 3 buttons
 - \blacktriangle for increase
 - \blacktriangledown for decrease
 - \blacktriangleleft shift flashing number to the left
- Alter the number 1250 so that it reads your correct calibration number.
- Press \ast Button. This enters your correct calibration number in the memory.
Meter returns to VACANT mode indicating calibration is completed.

Your Rates have been programmed as per instructions: Yes No
 If Yes, bypass step 4 Programming

INSTALLATION GUIDE

(Please file this guide for future rate changes)

RECORD TAXIMETERS MODEL CG II

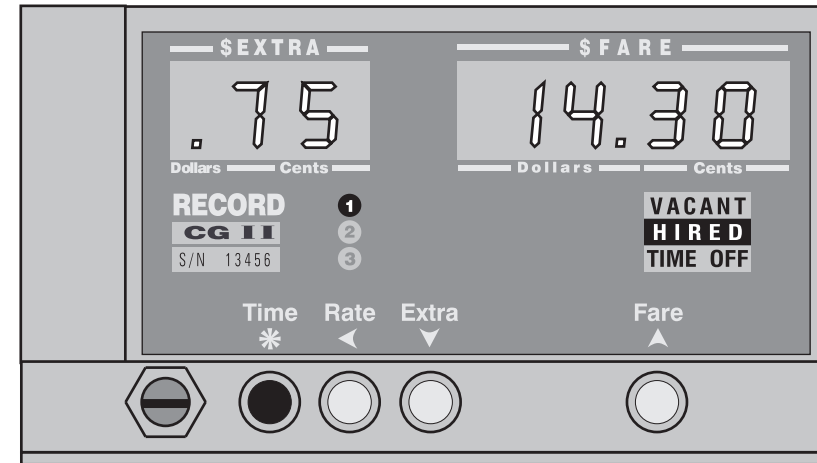

Installation of the Record CG II meter
 in 5 easy steps. Just follow these clearly illustrated steps
 and you are ready to collect your first fare.

For further information,
 Phone: (403) 258-2909
 Fax: (403) 255-4953
 1-800-661-1649
 Email: speedo@telusplanet.net
 Web: www.mrspeedometer.com
www.reimeter.com

The Meter that Goes the Distance