

# 1 Install Junction Box

Install under dash  
 Note: Allow air space around heat sink

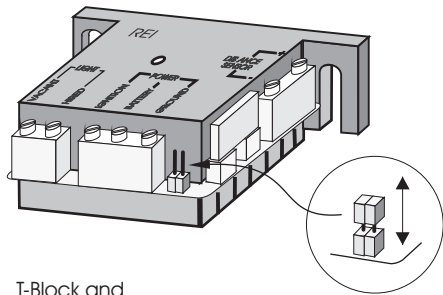

T-Block and Chrysler & GM Cars: - Use jumper  
 Ford Cars: - Remove jumper

# 2 Install Mounting Bracket

Install onto dash or other convenient location. Metal bracket can be used where necessary.

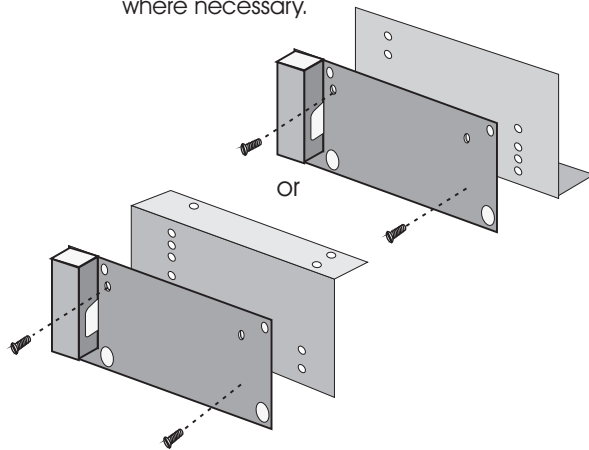

# 3 Electrical Hook-Up

Power connections:

- BATTERY terminal on junction box powers the meter. (3 Amp fuse protects meter)

- IGNITION terminal on junction box powers the roof light. (must be fused through an in-line fuse (10 Amp) )

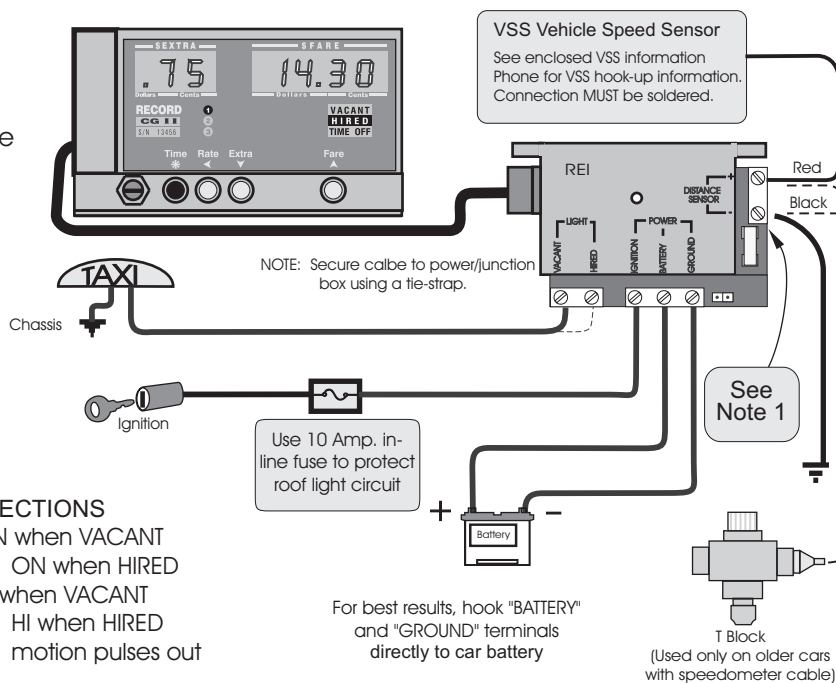

## JUNCTION BOX CONNECTIONS

LIGHT VACANT ON when VACANT  
 LIGHT HIRED ON when HIRED  
 DISPATCH VACANT HI when VACANT  
 DISPATCH HIRES HI when HIRED  
 MOTION motion pulses out

For best results, hook "BATTERY" and "GROUND" terminals directly to car battery

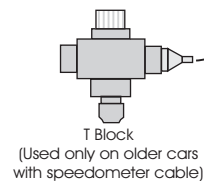

**NOTE 1:** Junction Box REV. G and subsequent MUST have a separate ground wire for mileage to work.

# 4 Programming

Your rates have been programmed as per instructions:

- Yes. Skip this section and go to Section 5
- No. Follow instructions below to program rates.

1. Make sure meter and wiring are properly installed as per steps 1,2, and 3.
2. Remove safety seal, seal screw, and hex insert.
3. Turn power to the meter ON and set meter to VACANT mode.
4. Temporarily insert rate setting pins into the small holes in hex insert slot. (See back page)  
 Meter should read: **P A t E S**
5. To start programming rates, press \* button. Enter rates using the 4 buttons as follows:  
 Press \* button to enter or leave memory  
 Press ▲ button to increase the value of the flashing number  
 Press ▼ button to decrease the value of the flashing number  
 Press ◀ button to move flashing digit to the next number on the left.  
 Procedure: use the ▲, ▼, ◀ buttons until meter reads the wanted value.  
 Press \* button to enter the value into memory.

6. Program rates as follows:

Example rate	Meter shows	Enter Function	
a) 1	<b>nr</b>	<b>1</b>	Number of rates to program (Max. of 3)
b) \$.cnts	<b>dP</b>	<b>2</b>	Decimal point location from R.H. e.g. 2 = \$\$\$\$.¢¢
c) \$0.25	<b>E t r</b>	<b>0.25</b>	Extras charge (0.00 will omit extras)
d) 7% tax	<b>t A</b>	<b>7.00</b>	Tax in % to be displayed. To omit tax display, program <b>t A</b> = 0.00 and <b>t t</b> = 0 in step e).
e) Tax in/add	<b>t t</b>	<b>0 1</b> or	If tax display desired in step 6d), then: 0 entry will split out tax at end of fare 1 entry will add tax at end of fare.
f) \$2.10	<b>1 1</b>	<b>2.10</b>	Flag rate
g) \$24/Hr.	<b>1 t</b>	<b>24.00</b>	\$ charge per hour
h) 105 meters	<b>1 1 d</b>	<b>0.105</b>	First drop distance, in meters or decimal fraction of mile or kilometer. *(See Example Below).
i) 105 meters	<b>1 2 d</b>	<b>0.105</b>	Following drop distances.
j) \$0.10	<b>1 2</b>	<b>0.10</b>	Fare increments

For single rate meters, proceed with steps 8, 9, & 10. (DO NOT complete step 7)  
 For multi-rate meters, proceed with step 7, then steps 8, 9, & 10.

7. If more than 1 rate was selected in step 6a) (nr 2 or 3), meter reads **2 1**, flag for rate 2  
 Program 5 values for rate 2 as per steps 6f)-j) **2 1**, **2 t**, **2 1 d**, **2 2 d**, & **2 2**  
 Program 5 values for rate 3 as per steps 6f)-j) **3 1**, **3 t**, **3 1 d**, **3 2 d**, & **3 2**
8. After last entry, meter returns to **E t r** (Extras charge programmed in 6c))
9. Press ▼ to review all rates for correct entries. If error is found in review rates, repeat rate setting procedure to correct error, starting at step 4.
10. Press \* Rate setting is now complete, and meter returns to VACANT

\* Example: Find decimal equivalent of 1/9 of a mile or kilometre.  
 Divide 1 by 9: 1 / 9 = 0.11111111.  
 Round off answer to 3 decimal places = 0.111: This is the correct value to enter.

5

## Determine Calibration Number

Install the meter and program the rates as per instructions.  
Determine the actual Calibration number of your car.

\* ◀ ▼ ▲ symbols on the meter face are used to indicate the buttons.

- Start with meter in VACANT mode (clock)

- Press \* Button. Meter reads: **SHIFT**

- Press ▼ Button. Meter reads: **TOTAL**

- Press ▼ Button. Meter reads: **CLEAR**

- Press ▼ Button. Meter reads: **TEST**

- Press \* Button. Meter reads: **F1 2**

- Press ▲ Button. Meter reads: **1250**

— nominal filter value  
— (This is a factory test value and is probably not right for your car)

- Drive to the start point of your test distance (1 Km or 1 mile) and stop.

- Press ▲ Button. Meter reads: **0**

- Drive the test distance. Meter is counting the mileage pulses. At the end of the test distance, stop the car.

- Press ▲ Button. Meter reads your correct calibration number (See Note 1)

- Write down number for later reference.

- Press \* Button. Meter returns to VACANT mode (clock)

6

## Enter Calibration Number in Memory

Enter Calibration Number into the meter

- Remove seal screw and hex insert

- Temporarily insert rate setting pins into the small holes in hex insert slot.

Meter reads: **RATES**

- Press ▲ Button. Meter reads: **CAL**

- Press \* Button. Meter reads: **F1 2** (Min. 1, Max. 7)

(filter value 2 is the correct setting for nearly all cars, (See Note 2))

- Press \* Button. Meter reads: **1250**

- With the 3 buttons ▲ for up

▼ for down

◀ shift flashing number to the left

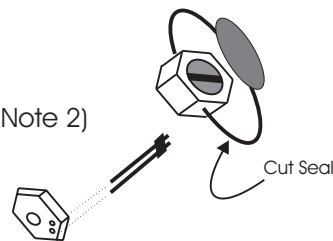

Alter the number 1250 so that it reads your correct calibration number. (See Note 2)

- Press \* Button. This enters your correct calibration number in the memory.

Meter returns to VACANT mode (clock)

The meter is now ready for your first fare.

NOTE 1: Factory standards for all cars are 2000, 4000, or 8000 pulses/mile or 1250, 2500, or 5000 pulses/Km.

The calibration number for your car should be relatively close to one of the above numbers. If it is not, the calibration might be wrong. If the test run is repeated, the calibration number should remain the same.

NOTE 2: Filter F1 and calibration number must have a value entered for Mileage Charges to work.

Your Rates have been programmed as per instructions:

Yes  No

If Yes, bypass step 4 Programming

# INSTALLATION GUIDE

(Please file this guide for future rate changes)

## RECORD TAXIMETERS MODEL CG II

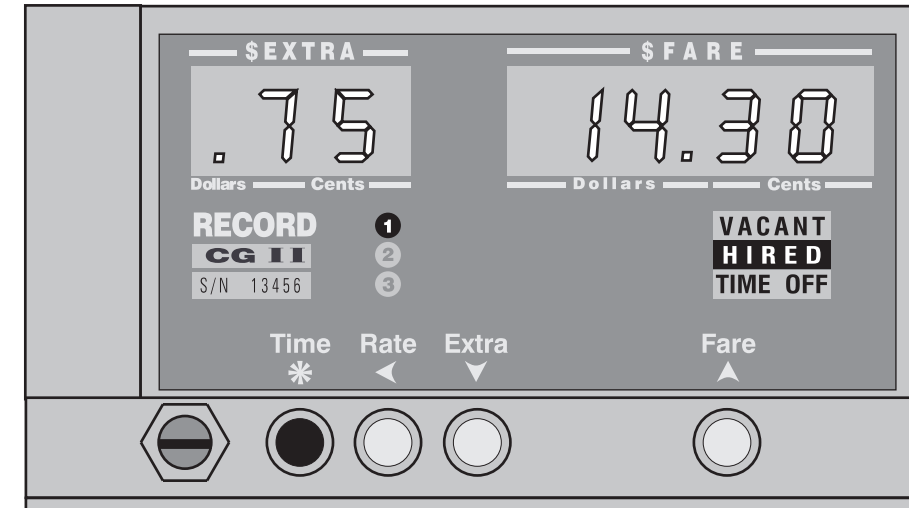

Installation of the Record CG II meter  
in 6 easy steps.

Just follow these clearly illustrated steps  
and you are ready to collect your first fare.

For further information,

Phone: (403) 258-2909

Fax: (403) 255-4953

1-800-661-1649

Email: [speedo@telusplanet.net](mailto:speedo@telusplanet.net)

Web: [www.mrspeedometer.com](http://www.mrspeedometer.com)

[www.reimeter.com](http://www.reimeter.com)

*The Meter that Goes the Distance*